

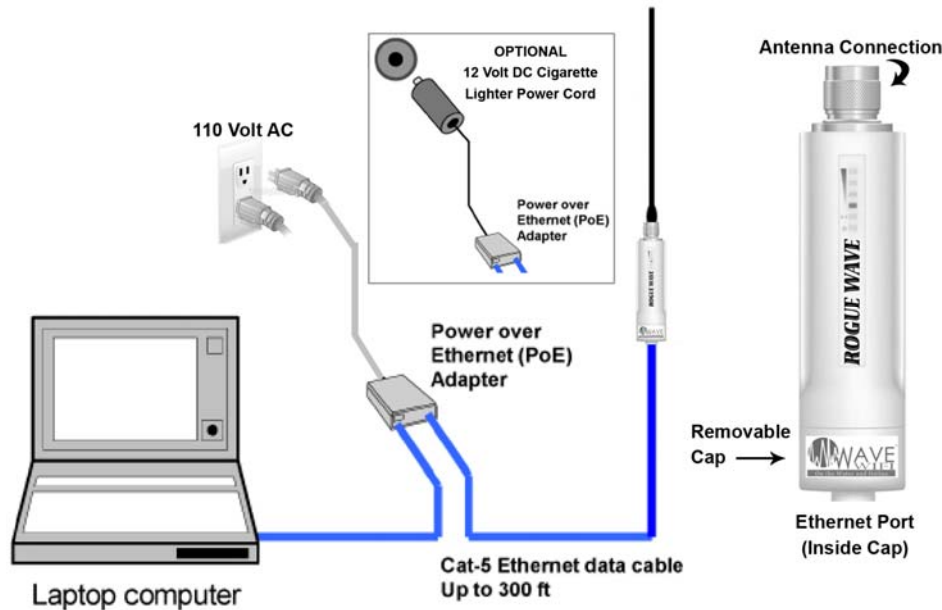

# Rogue WAVE - Quick Start Guide

The Rogue is a ship to shore Ethernet bridge. Computers connected to the Ethernet network can scan for, and connect to, HotSpots that provide a pathway to the Internet. If you need more information than this Quick Start Guide provides then please see the comprehensive manual available on the CD shipped with this product.



Secure the antenna supplied with the kit to the Rogue's 'N' connector. Unscrew the protective cap from the other end of the Rogue and pass one end of the supplied Ethernet cable through the cap. Plug the Ethernet cable into the Rogue and securely replace the cap inserting the rubber grommet around the cable and the cap.

Keeping the antenna away from metal objects (i.e. mast), temporarily mount the Rogue on a stanchion or rail using the Velcro band included with the kit

The Rogue utilizes Power over Ethernet (PoE). Care must be taken to insure that the Ethernet cable from the Rogue is inserted into the power injector marked '**ROGUE.**' The short Ethernet jumper is inserted into the power injector marked '**COMPUTER.**'

Connect the Rogue to **12 volts only** using either of the 120V-AC to 12V-DC Power Supply or the optional 12V-DC power

supply and adapter (cigarette lighter cable and plug).

**Caution: Failure to properly connect the 12-volt power supply could damage the computer.**

**Note:** While the Rogue's light-weight, compact, weather resistant design makes it the ideal portable Ethernet converter/Wireless Bridge for temporary Internet access, prolonged exposure to the marine environment will cause premature deterioration of the internal circuitry and shorten the life of the unit. The Wave WiFi Warranty Policy specifically states that the warranty is void if the failure is attributable to misuse, mishandling, improper installation, alteration (including removing or obliterating labels) and opening or removing external covers.



# Rogue WAVE - Quick Start Guide

## Logging-in to the EC Unit

Connect your computer Ethernet port to the EC-unit Ethernet cable. When the computer has obtained an IP address from the EC-unit, open the browser. You can check that your computer has an IP address by opening your computer's network icon, then see if it is 'connected'. The browser can be MS Internet Explorer, Firefox or Netscape.

Type in the URL: **http://WaveWiFi.com**

After a short delay, the network scan page will open. The web page will look like the one shown below.

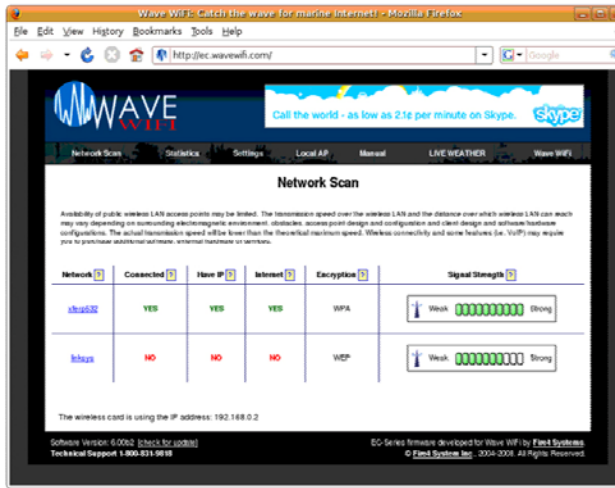

If you are connecting wirelessly to an EC-AP unit then you should look for the wireless network with the name:

### Wave WiFi EC Series

If your computer is not already connected to this network then click on CONNECT. Once connected, open your browser with the URL above

Now that you are able to connect your computer to the EC-unit a few simple configuration steps are required. Please turn this page over to proceed.

## Scanning for Hot-Spot Networks

Click on the button NETWORK SCAN as shown on the screen below. A list will appear below the button showing the networks that have been found. Because the protocol handshake between the EC unit and a remote access point can take from 30 seconds to two minutes, wait two minutes and click the button again. It is likely that additional networks will be listed.

The list of HotSpot wireless networks is ordered by signal strength: the strongest signals are indicated by the color and length of the bar display. It is likely that with subsequent scans, the bottom of the list may change frequently due to the weak signal strength of the access points. All other functions of the EC unit are accessed through the menu at the top of the screen

To select the HotSpot network with which you want to connect, click on the HotSpot name (SSID). This is shown in the left hand column. The EC-unit will negotiate a connection with the remote HotSpot. During this process the timer will be counting as shown on the screen below. Do not click on anything until this process is completed. If the HotSpot access point is able to provide an IP address to the EC unit, the red NO in the IP column will change to a green YES.

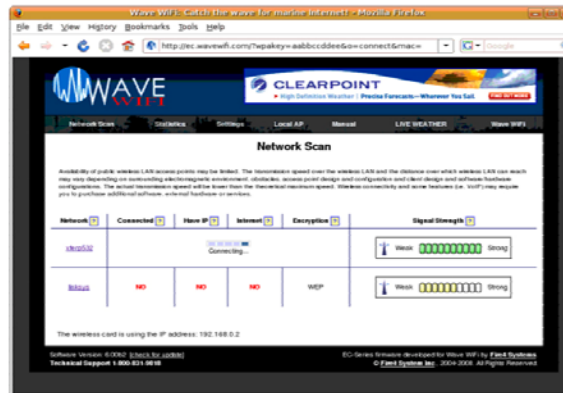

## Configuring the EC Bridge Interface

In some cases it is not possible to log-in to the HotSpot access point because it has been configured in a non-standard way. In this case, the Bridge Interface configuration can be changed to gain HotSpot access.

Clicking on SETTINGS on the scan page opens the screen below. DISABLE EC FIREWALL removes your protection from access by other network users. However, it may be necessary to disable this feature to access some HotSpots where the access point has been configured incorrectly. USE STATIC IP ADDRESS may be necessary for some HotSpots where access is billed and controlled by giving users IP addresses.



## Reset Network Settings when Moving Between Networks

The function of the RESET NETWORK SETTINGS button is to clear HotSpot information from the EC unit's internal registers. As the EC scans for networks and connects to networks, information about the networks is stored in internal memory. Click on RESET NETWORK SETTINGS when moving to a different geographic area. This will facilitate the search for new networks.